



DCM50xxx/57xxx Series

DC Brush Servo Motors



Product Description

The DCM50xxx/57xxx series motors are permanent magnet DC brush servo motors. The motors are ideal for cost sensitive applications. They include an attached encoder which provides position feedback to controllers.

Features

High performance (Smooth operation, High precision

and Low noise)

- | Low cost
- | Small disturbance
- | Encoder optional (1000 line or 500 line), Positional error can be eliminated to one pulse
- | Mounting dimensions of DCM57xxx brush servo motors are the same as those of NEMA frame size 23 motors

Typical Applications

- | Engraving machines, Cutting machines, Jet-ink machines
- | Experimental installations and Instructional machines
- | Measuring devices, such as Imager, Analytic Instruments, etc.
- | Electronic packaging equipments and Loading and unloading devices
- | Medical instruments

Brush Servo Motor Specifications

No.	Parameter	Symbol	Units	DCM50202A	DCM57202	DCM5x205	DCM 5x207
1	Continuous Torque (Max)	T_C	N·m	98.9×10^{-3}	98.9×10^{-3}	218.9×10^{-3}	353.1×10^{-3}
2	Peak Torque (Stall)	T_{PK}	N·m	0.76	0.76	1.59	2.90
3	No-load Speed	S_{NL}	rpm	4600±10%	4600±10%	4000±10%	3600±10%
4	Rated Speed	S_R	rpm	3500	3500	3000	2900
5	Rotor Inertia	J_M	kg·m ²	1.62×10^{-5}	1.62×10^{-5}	3.11×10^{-5}	4.73×10^{-5}
6	Maximum Winding Temperature	θ_{MAX}	°C	155	155	155	155
7	Thermal Impedance	R_{TH}	°C/watt	9.00	9.00	7.30	4.98
8	Motor Weight (Plus encoder)	W_M	g	694	754	1182	1338
9	Motor Length (Plus encoder)	L_1	mm	121±2	129±2	161±2	196±2
10	Rated Voltage	E	V	24	24	24	30.3
11	Rated Current	I	A	1.79	1.79	2.95	3.94
12	Torque Constant	K_T	N·m/A	55.1×10^{-3}	55.1×10^{-3}	74.2×10^{-3}	89.7×10^{-3}
13	Resistance	R_T	Ω	1.73	1.73	1.11	0.93
14	No-Load Current	I_{NL}	A	0.5	0.5	0.8	0.6
15	Peak Current (Stall)	I_P	A	13.9	13.9	21.6	32.6
16	Encoder Specification	—	Lines/rev	500/1000	500/1000	500/1000	500/1000



Mechanical Specifications

Mechanical specification of DCM57202 motor (plus encoder) is shown as Figure 1.

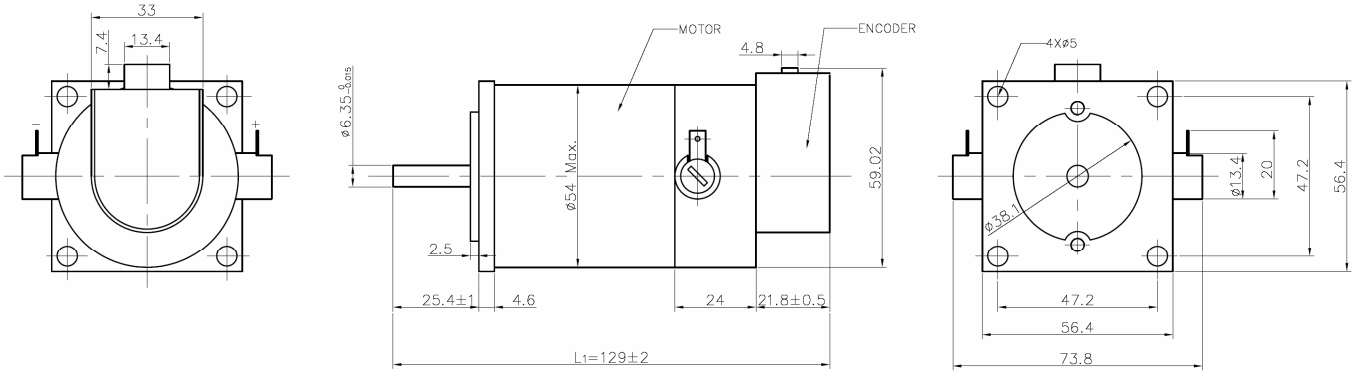

Figure 1: Mechanical specification of DCM57202 motor (plus encoder)

Mechanical specification of DCM57205 motor (plus encoder) is shown as Figure 2.

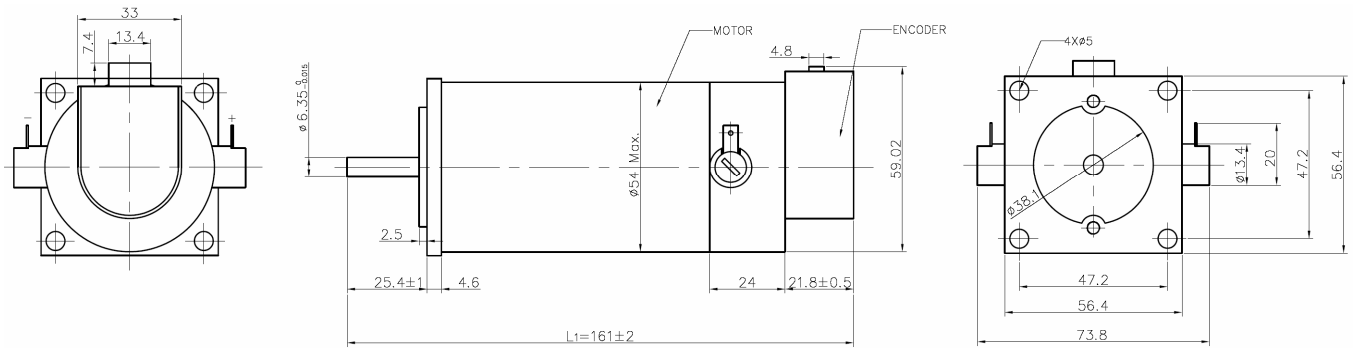

Figure 2: Mechanical specification of DCM57205 motor (plus encoder)

Mechanical specification of DCM57207 motor (plus encoder) is shown as Figure 3.

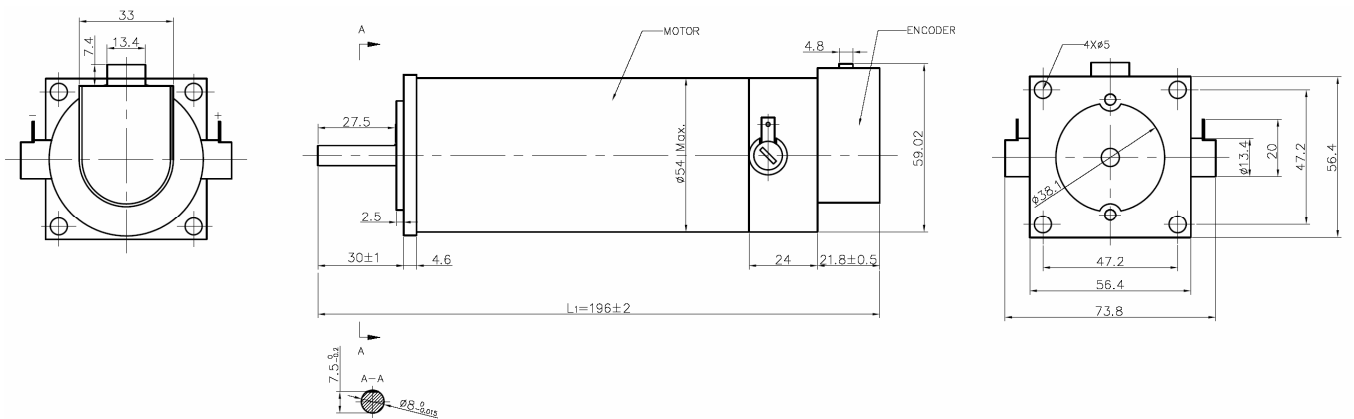

Figure 3: Mechanical specification of DCM57207 motor (plus encoder)



Mechanical specification of DCM50202A motor (plus encoder) is shown as Figure 4.

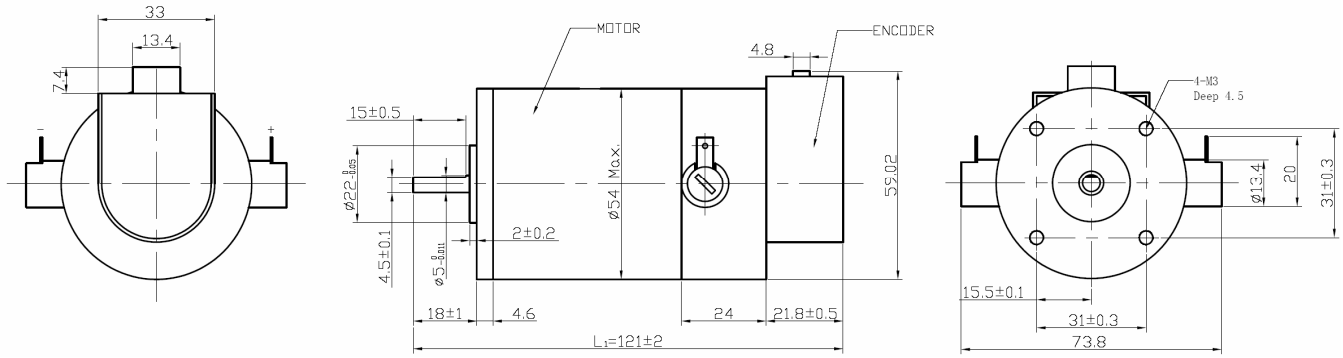

Figure 4: Mechanical specification of DCM50202A motor (plus encoder)

Mechanical specification of DCM50205 motor (plus encoder) is shown as Figure 5.

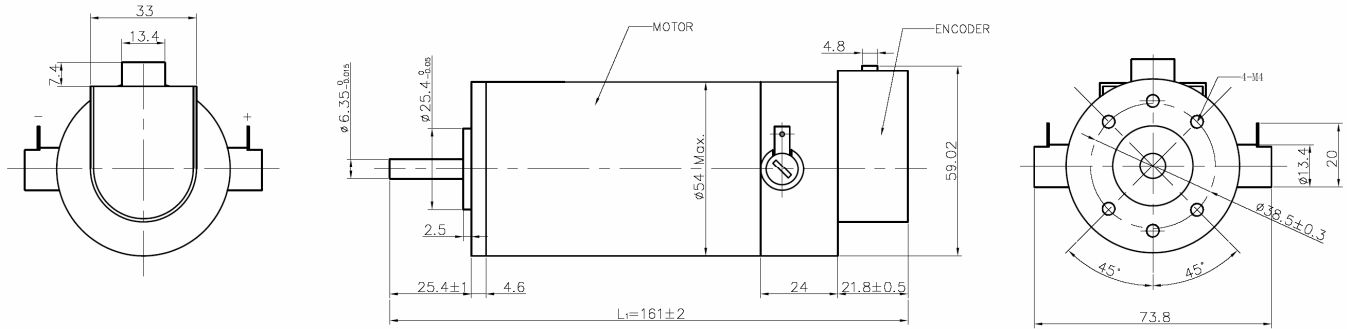

Figure 5: Mechanical specification of DCM50205 motor (plus encoder)

Mechanical specification of DCM50207 motor (plus encoder) is shown as Figure 6.

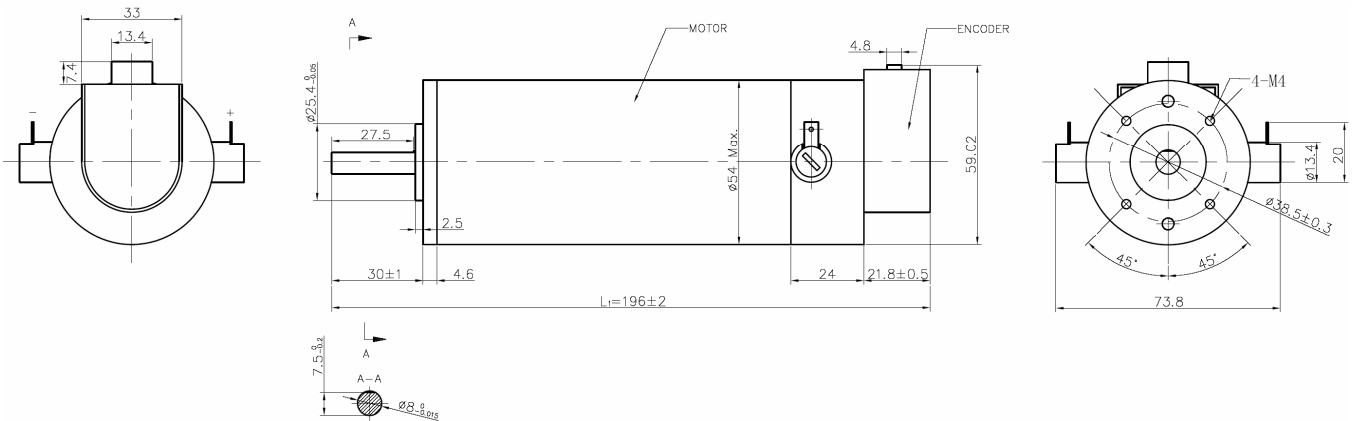

Figure 6: Mechanical specification of DCM50207 motor (plus encoder)



Encoder (Line Count and Signal Type Optional)

DCM5xxxx series motors include an attached encoder, and the user can select line count and signal type of the encoder. The DCM5xxxx-1000 models include a 1000 line single-ended encoder and the DCM5xxxx-500 models include a 500 line single-ended encoder; while the DCM5xxxxD-1000 models include a 1000 line differential encoder and the DCM5xxxxD-500 models include a 500 line differential encoder. All encoders on the standard models have A signal and B signal. No Z signal is offered by the standard models, please specify the requirement when placing an order if the user needs an encoder which has Z signal.

I Connection Chart for Single-ended Encoder:

Pin	Colour	Connection (DCS303, DCS810/DCS810S, DCS811)
1	Blue	Channel B (EB/EB+)
2	Yellow	Channel A (EA/EA+)
3	Red	VCC (E+5V/E+5V)
4	Black	Ground (EGND/EGND)
5	Green	Index/NC (NC/NC)

I Connection Chart for Differential Encoder:

Pin	Colour	Connection (DCS810, DCS811)
1	Black	Channel A+ (EA+)
2	Blue	Channel A- (EA-)
3	Yellow	Channel B+ (EB+)
4	Green	Channel B- (EB-)
5	Red	VCC (E+5V)
6	White	Ground (EGND)

Typical Connections

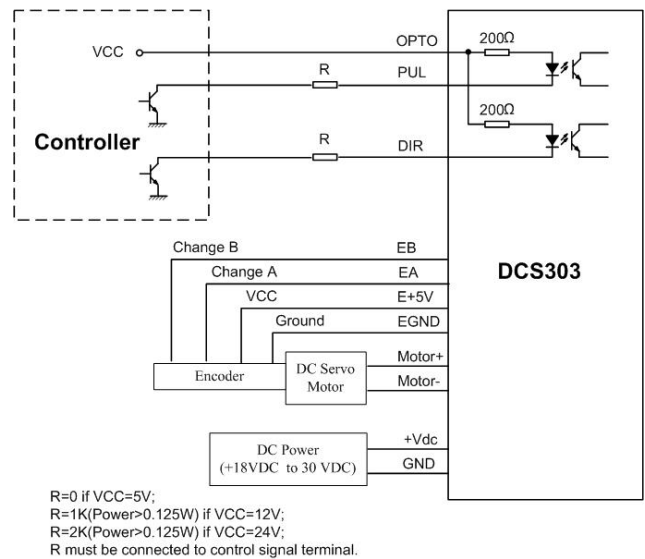

Figure 7: Typical connections of DCM5xxxx series motors and DCS303 servo driver

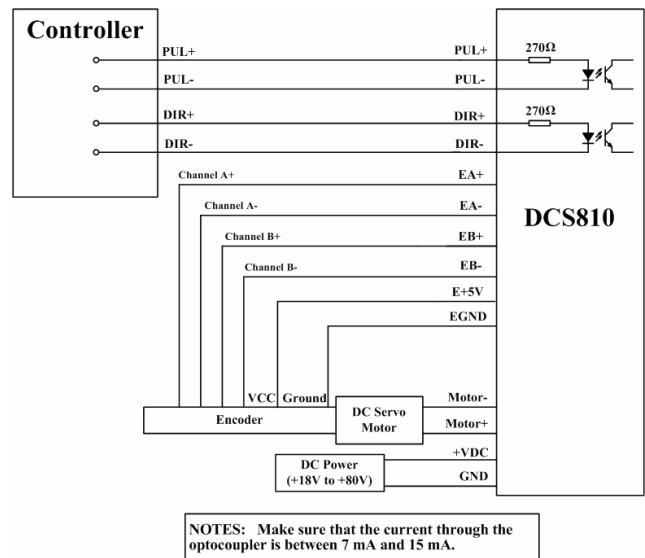

Figure 8: Typical connections of DCM5xxxx series motors and DCS810 servo driver

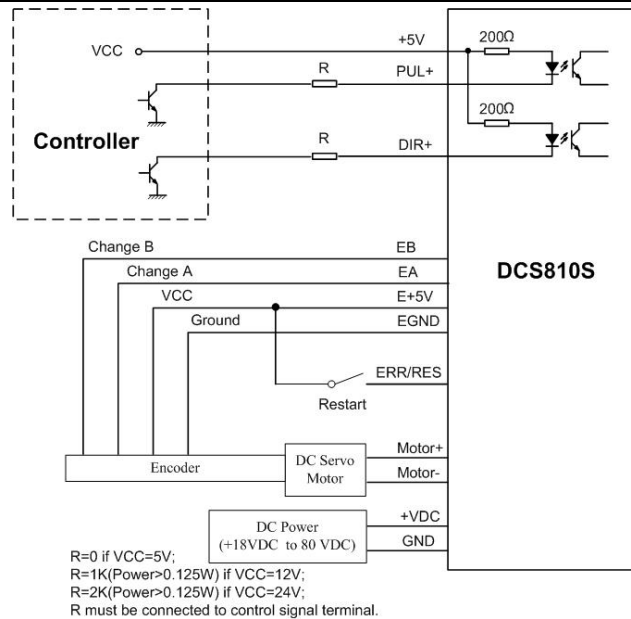

Figure 9: Typical connections of DCM5xxx series motors and DCS810S servo driver

Speed-Torque Characteristics

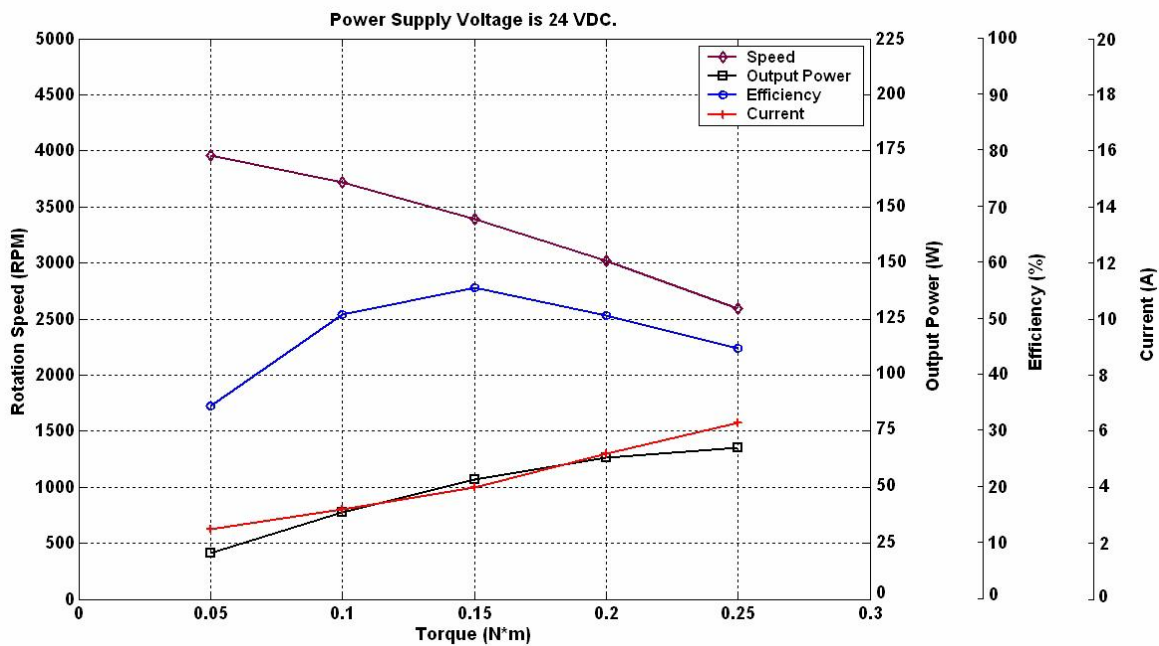

Figure 10: Speed-torque characteristics of DCM5x202 and DCM50202A

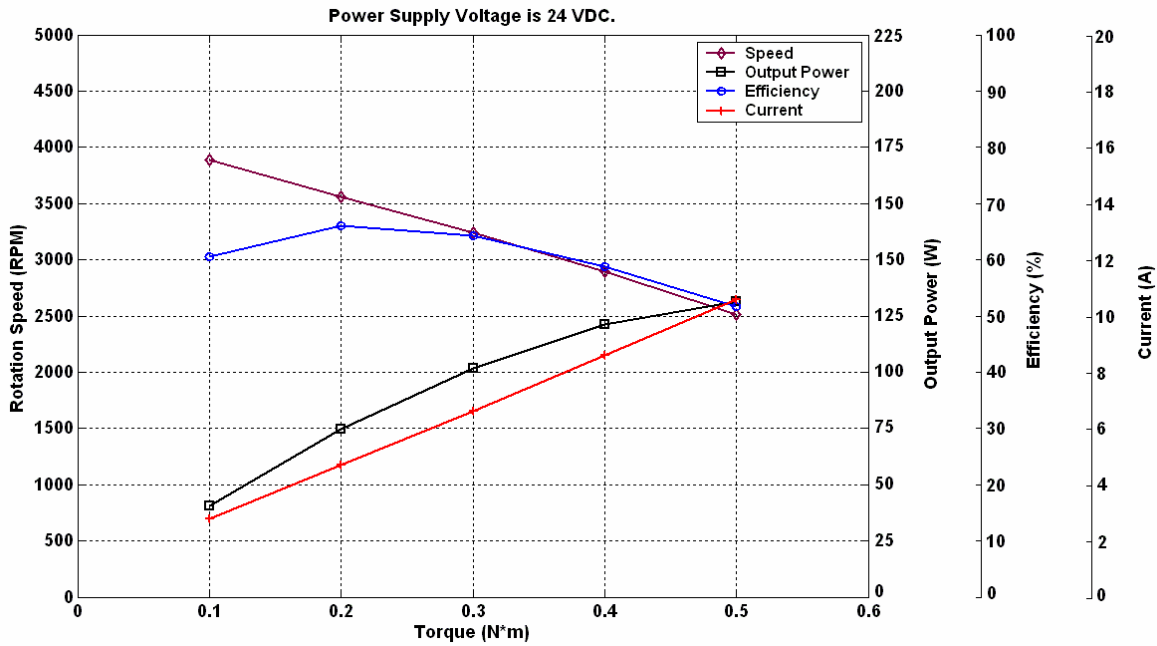

Figure 11: Speed-torque characteristics of DCM5x205

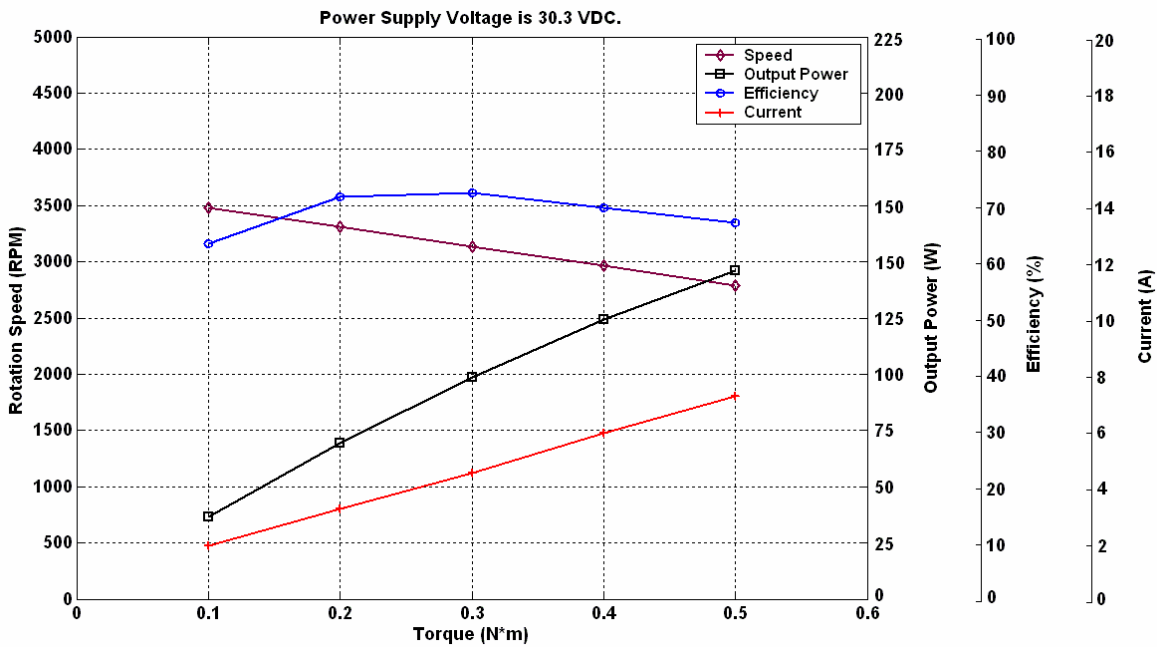

Figure 12: Speed-torque characteristics of DCM5x207



Order Information

- U DCM50xxx-1000 is a bolting motor including a single-ended 1000 line encoder, such as the DCM50202A-1000 motor, the DCM50205-1000 motor and the DCM50207-1000 motor.
- U DCM50xxx-500 is a bolting motor including a single-ended 500 line encoder, such as the DCM50202A-500 motor, the DCM50205-500 motor and the DCM50207-500 motor.
- U DCM57xxx-1000 is a flange connected motor including a single-ended 1000 line encoder, such as the DCM57202-1000 motor, the DCM57205-1000 motor and the DCM57207-1000 motor.
- U DCM57xxx-500 is a flange connected motor including a single-ended 500 line encoder, such as the DCM57202-500 motor, the DCM57205-500 motor and the DCM57207-500 motor.
- U DCM50xxxD-1000 is a bolting motor including a differential 1000 line encoder, such as the DCM50202AD-1000 motor, the DCM50205D-1000 motor and the DCM50207D-1000 motor.
- U DCM50xxxD-500 is a bolting motor including a differential 500 line encoder, such as the DCM50202AD-500 motor, the DCM50205D-500 motor and the DCM50207D-500 motor.
- U DCM57xxxD-1000 is a flange connected motor including a differential 1000 line encoder, such as the DCM57202D-1000 motor, the DCM57205D-1000 motor and the DCM57207D-1000 motor.
- U DCM57xxxD-500 is a flange connected motor including a differential 500 line encoder, such as the DCM57202D-500 motor, the DCM57205D-500 motor and the DCM57207D-500 motor.

Note: No Z signal is offered by the standard models, please specify the requirement when placing an order if the user needs an encoder which has Z signal.